

DESIGN PROJECT 2: SHIFTING AND PLANETARY GEARBOXES

*ENGR3330
Mechanical Design
Olin College of
Engineering Oct. 8,
2018*

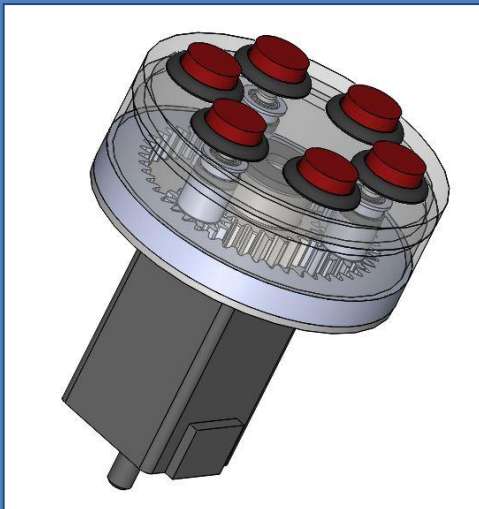

Christina Segar

Grade:	_____	\ 100
Exec Summary:	_____	\2
Preliminary Design:	_____	\10
FBDs:	_____	\10
CAD Models:	_____	\20
FEA/FOS:	_____	\10
Optimize Parts:	_____	\15
Manufacture DWGs:	_____	\20
Assembly DWGS:	_____	\10
BOM:	_____	\3

Executive Summary:

The shifting gearbox is inspired by a manual transmission design which involves shifting between gear engagements to obtain different gear ratios. This could be applicable in mechanical systems such as powered wheelchairs, where different levels of torque may be needed for different activities such as ascending hills or navigating bumpy roads. For this design I wanted to make the system compact while still allowing the gearing to be clearly visible. This led to a multiple stage transmission transferring motor power on a 12T gear to a 60T gear to obtain a high torque initial reduction. The 60T gear is linked to 36T and 24T gears which connect to 36T and 48T gears, respectively. The dog gear slides back and forth on a hex shaft to engage one of the output gears that are otherwise freely spinning on a round shaft. Finding a configuration that would allow the two shafts to line up while also keeping pitch diameters tangent proved to be difficult when paired with a limited library of realistically available gear types. For future iterations I would suggest further investigation into the selector gear design as this one is hard to come by with respect to manufacturing availability.

The planetary gearbox is modeled off of a simple planetary design in which the sun gear is attached to the motor and the three planet gears are attached to a top plate that outputs the motion of the system. This gearbox was created to work within the assistive technology realm, where it could be used to rotate several buttons to be accessed from one position. This can be especially helpful for someone with limited wrist or arm control, so that they can perform more tasks, especially from a fixed position within a wheelchair. The gearbox is powered by a DC stepper motor so that the button table is position controlled, meaning a program can track which button is in front of the user or rotate to pre-set positions. Initial designs of this contained planet gears attached on one

side and free floating, but a second plate was added so that the gear shafts would be constrained on either end with bearings. Future versions could incorporate other position control actuation to allow the system to move about additional axes in conjunction with the current rotational capability.

Preliminary Design Sketch and Product Description:

The shifting gearbox design process began with initial sketches to determine the position of the gears relative to each other and mark out what parts would need to be created. The general design involved an input shaft from the motor or engine, a lay shaft, and an output shaft to the differential.

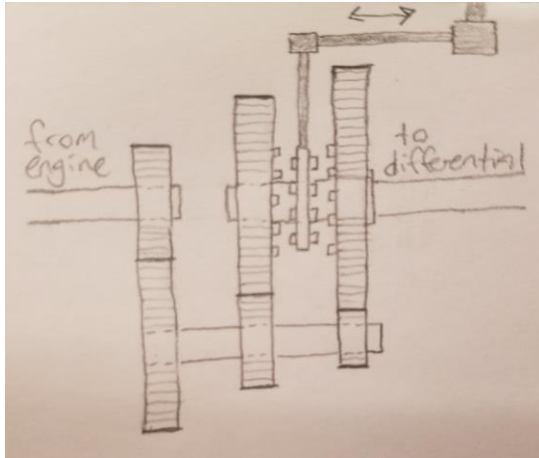

The next step involved

careful calculation that defined the fixed constraints that were modified to produce practical gearing options. A pitch of 24 was chosen due to wide availability within McMaster-Carr and a center distance between the two axes was decided to be 1.5in because initial calculations showed this would allow for a wide array of combination options. Knowing these, gears could be paired to calculate expected output

Total Ratio		5	10
Teeth	12	36	48
Pitch	24	24	24
Pitch Diameter	0.5	1.5	2
Teeth	60	36	24
Pitch	24	24	24
Pitch Diameter	2.5	1.5	1
Center Distance	1.5	1.5	1.5
Intermediate Ratio	5		

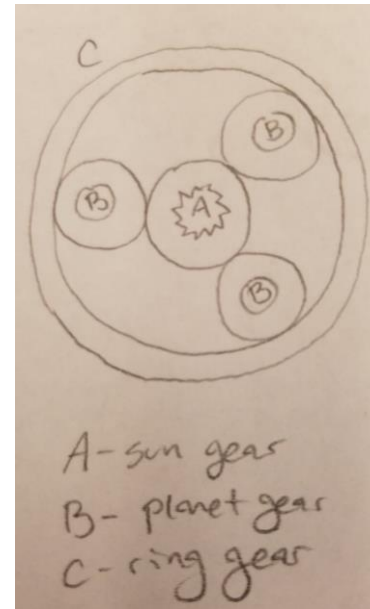

The planetary gearbox was initially a simple concept sketch identifying the key components of a planetary gearbox. From this, a concept design was created that showed that a larger center gear would be connected to a powered shaft. The connecting planet gears would run along an internal spur gear. A geometric sketch in Solidworks similar to the one on the left was used to determine what gearing options would with this particular arrangement. Three circles were created tangent to one central circle, acting as the pitch diameters of the planet and sun gears. The three gears were all made tangent to a larger circle concentric to the initial one that would act as the pitch diameter of the internal gear. These geometric models could be easily modified to determine what gearing options

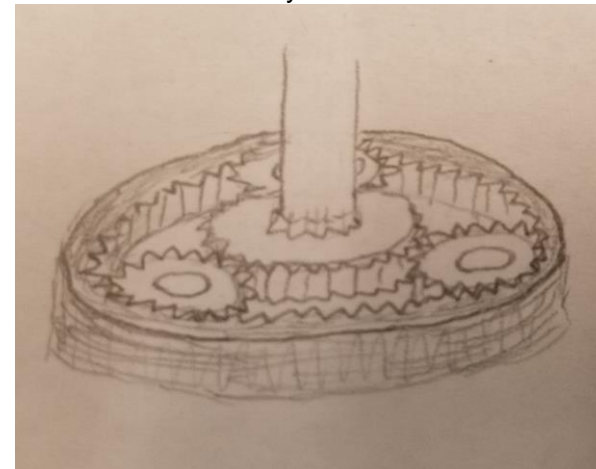

ratios. The final gearing choices produced output ratios of 1:5 and 1:10 reductions.

would give desired gear ratios. This model was more based off of available gears given that internal spur gears are less plentiful in options.

Free Body Diagrams of all Critical Parts:

The line-up of gearing and corresponding pitch diameters of the gears within the shifting gearbox are shown to the right.

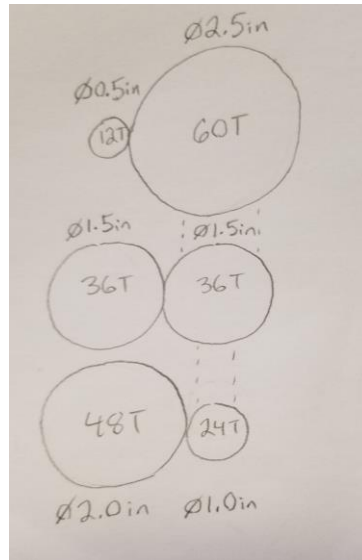

The shifting gearbox involved several gearing reductions and therefore had more complex free body diagrams and corresponding force calculations than the planetary gearbox would have. The initial forces acting on the 12T gear attached to the motor are shown below. These result in a determined force acting tangent to the gear on the surface of the individual teeth. This force can then be transferred to the next gear in the link, the 60T gear. This is on a hex rod fixing its rotational motion with that of the 36T and 24T gears. The force then applied on the teeth of the final gears, the 36T and the 48T are

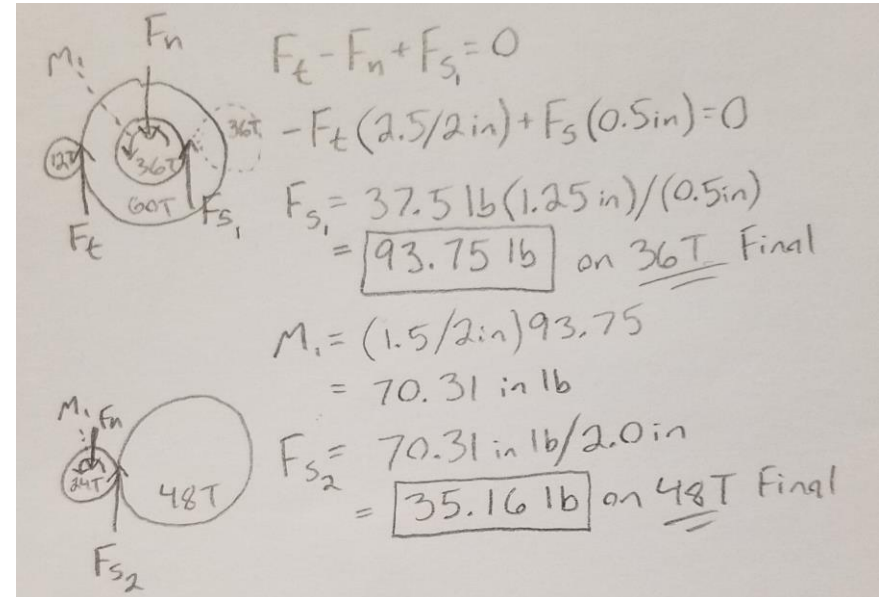
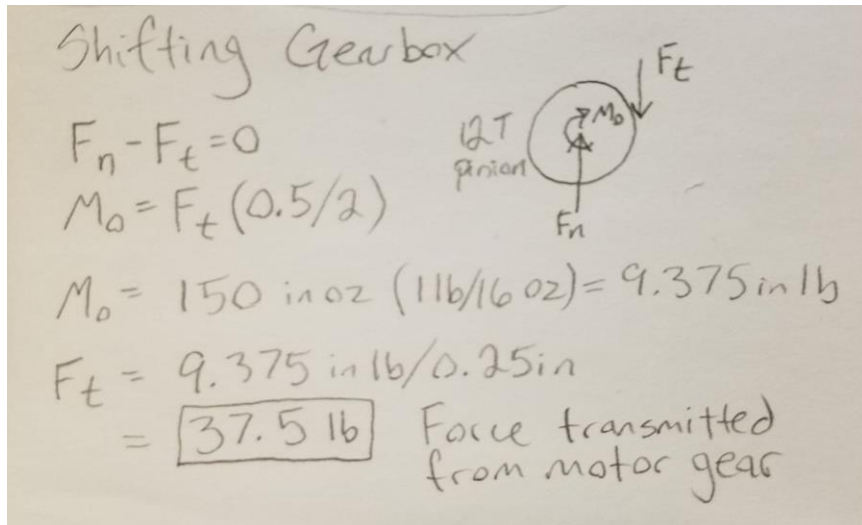

analyzed in the FEA section to determine stresses acting on these gears.

The planetary gearbox had a simple gear interaction between a driving gear and three driven gears. This is modeled such that the resulting force on the teeth of the planet gears is analyzed in the FEA section to account for stresses applied.

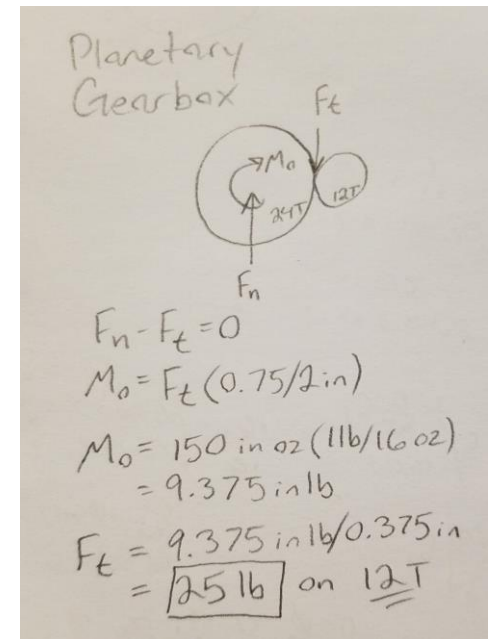

CAD Models (annotated summary of major parts):

The **shifting gearbox** consists of a DC motor with an attached pinion, a lay shaft, and an output shaft. The gearbox is sandwiched between two custom plates which are held apart by four standoffs positioned to

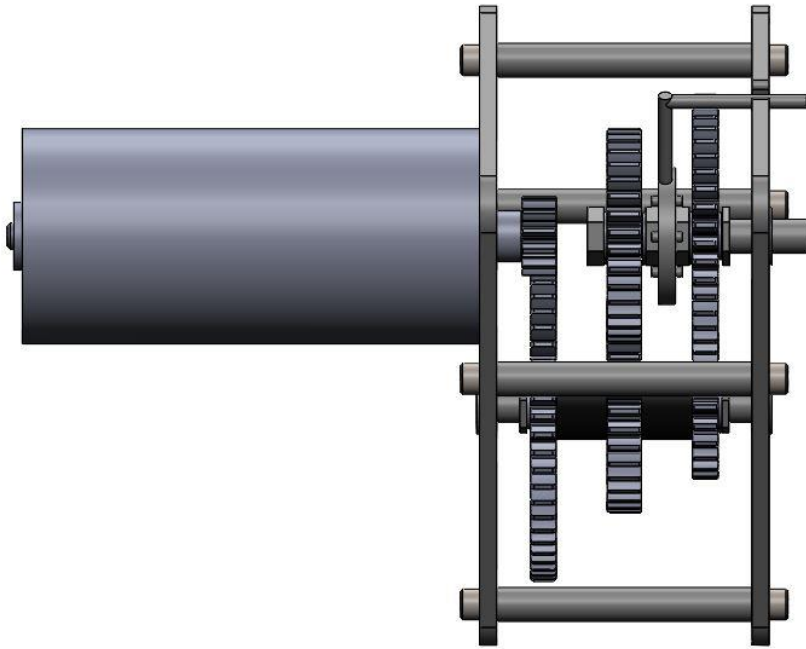

distribute forces without intersecting with gear motion. A selector gear is used to engage with one of the two gears on the output shaft.

The first shaft (shown right, top) includes a 60T gear, a 36T gear, and a 24T gear. These all sit on a hex shaft that allows them to be linked in motion without need for any pins or set screws. Two spacers keep the middle gear in position while retaining rings on either side constrain the first and last gears. The shafts include round portions to interface with bearings more easily (hex bearings tend to be significantly more expensive than round bored ones). Either end includes flanged bearings that press into the outer plates from the outside.



Thus, the selector gear moves linearly along the shaft in order to select the desired output gear. The first gear, the 36T produces an overall 1:5 reduction, while the other gear, the 48T, produces a 1:10 reduction from the motor.

The clock cage plates on either side are almost the same except for slight differences in shaft hole diameters and the addition of the selector gear rod slot on the bottom plate (farther from the motor). The holes allow for press fitting of bearings to constrain each of the axles. The contours of the plate match that of the gears such that there are no exposed

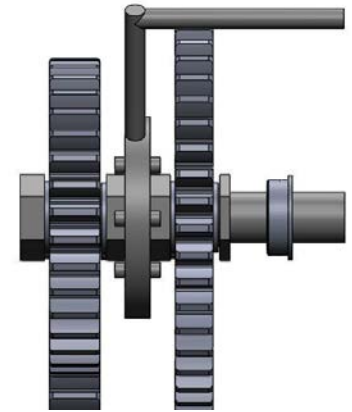

teeth beyond the profile of the plates themselves. This is a cautionary design choice to prevent teeth intersecting with any parts that are placed coincident with the sides of the gearbox.

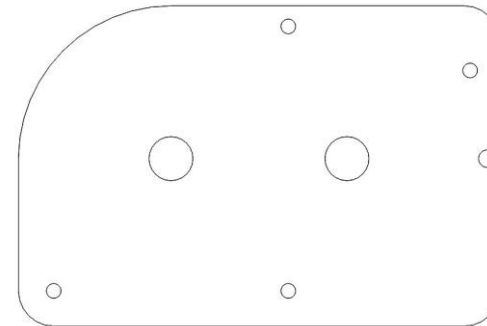

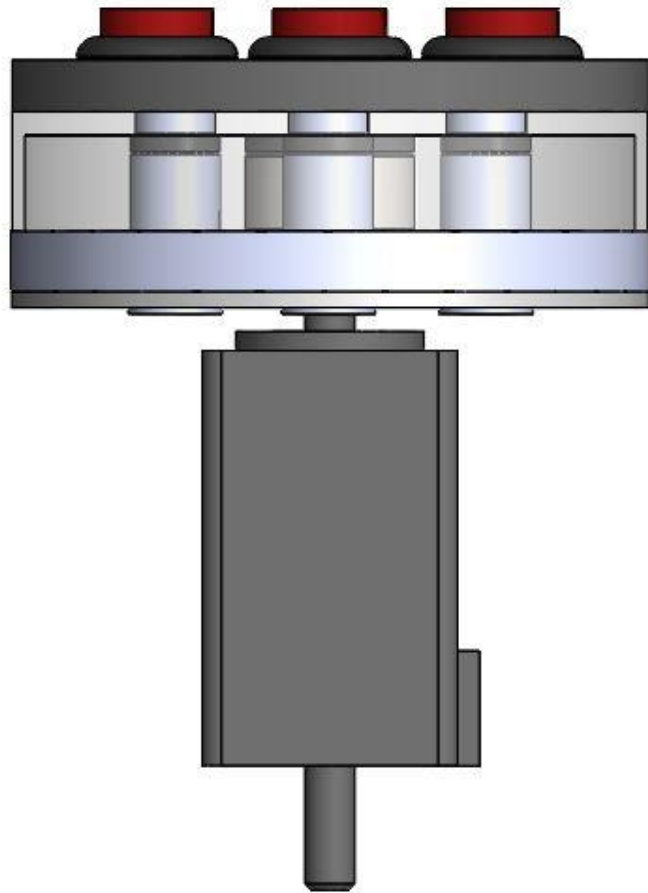

The planetary gearbox is powered by a DC stepper motor that allows for precise position control. This transfers motion to a central gear that spins three planet gears which in turn rotate the top plate that hold the buttons.

The gearing includes one 24T gear and three 12T gears, creating a reduction ratio of 2:1. These are each constrained on their individual axes with spacers and retaining rings to keep the gears in place along

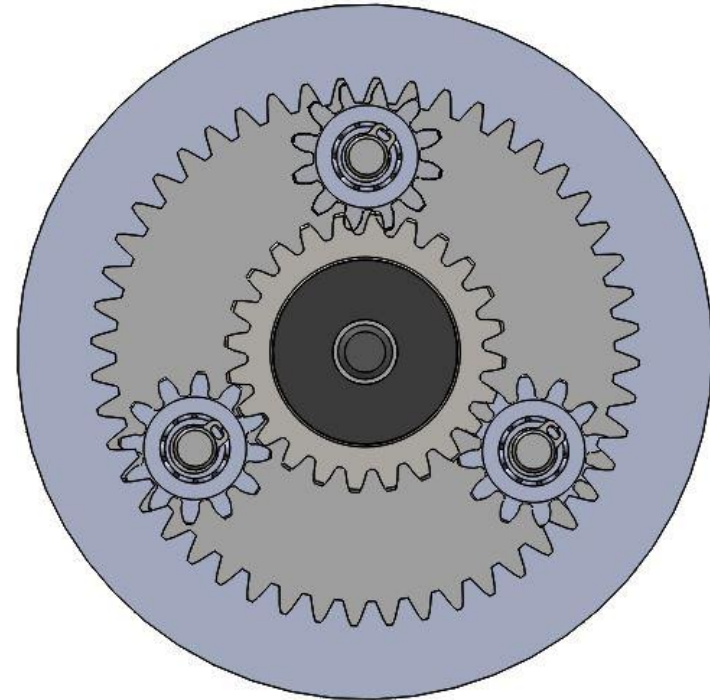

the shaft. The shafts themselves are round, allowing the gears to spin freely, and contain retaining ring grooves on either end.



The remaining portion of the mechanical assembly incorporated three pieces to enclose the gearbox and constrain pieces on either side. The first of these pieces is a simple round plate that attaches to the bottom of the gearbox so that the axles of the gears can be constrained on

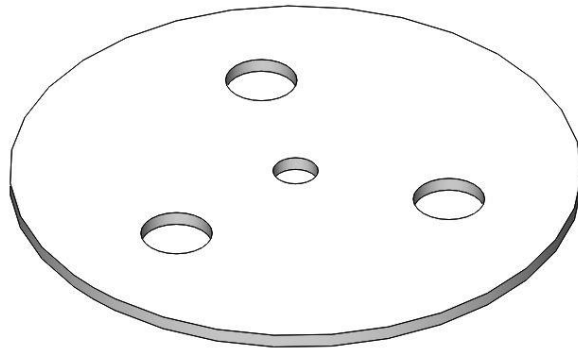

both ends with bearings. This includes three holes for press fit of these bearings as well as a middle clearance hole for the motor shaft.

The next piece is the middle containment that acts as a wall to the gearbox to protect the internal components. Frequently gearboxes are well-greased and it is undesirable to have this grease spread elsewhere on the assembly or conversely for anything to get caught in the gears. The three holes interface with the corresponding ones on the bottom plate.

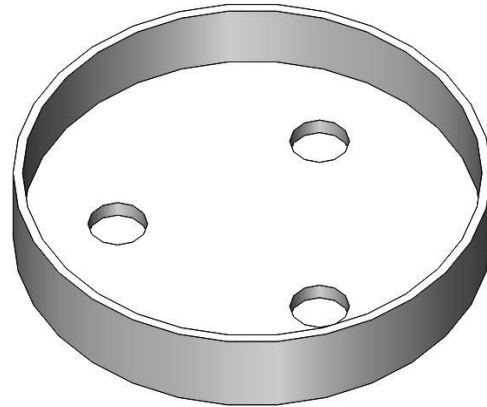

Finally, the top plate sits just above the top of the shaft extrusions to allow room for clearance. This acts both as the cap to the system while also holding the six buttons that rest on the platform. These in turn rotate as a result of the stepper motor input.

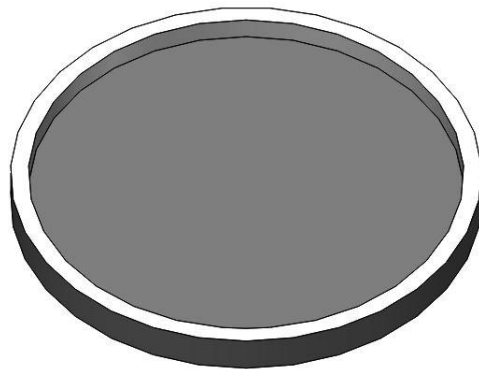

FEA/Factor of Safety Analysis of all Critical Parts:

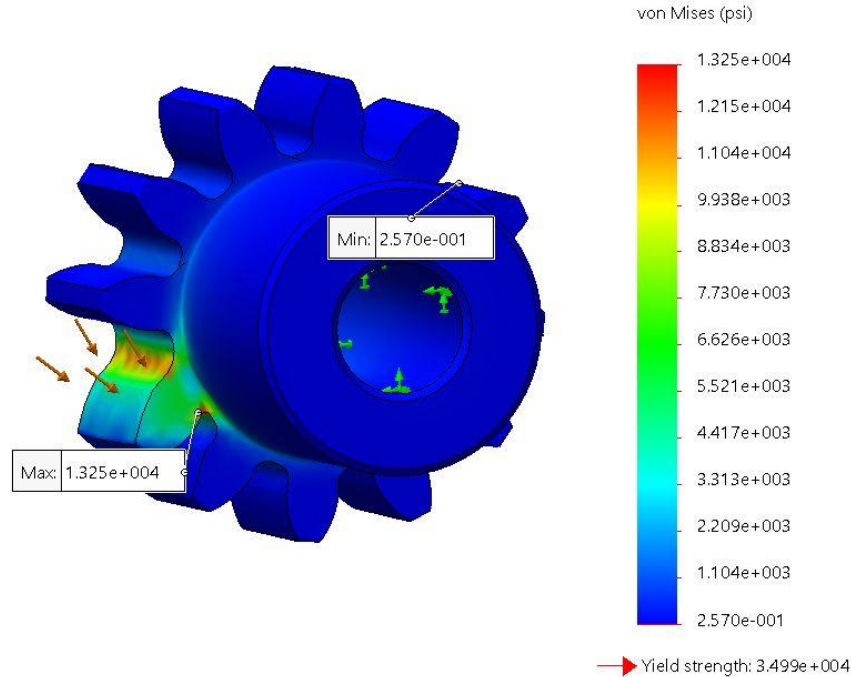

This 12T gear (shown above) is part of the planetary gearbox system. The forces acting on it represent the force interactions between the central 48T motor gear and each of the corresponding planet gears. These stress values seem to be within reasonable tolerances given the application of the gears in transmitting torque and motion.

The 36T gear (shown right, top) is the first of the two final stage options in the shifting gearbox. This is the force on a single tooth as applied by the 36T gear on the input shaft. The stress forces here also seem reasonable.

The 48T gear (shown right, bottom) is the final gear in the shifting gearbox transmission. This one is acted on by the 24T gear on the input shaft. It experiences less force on each individual tooth due to

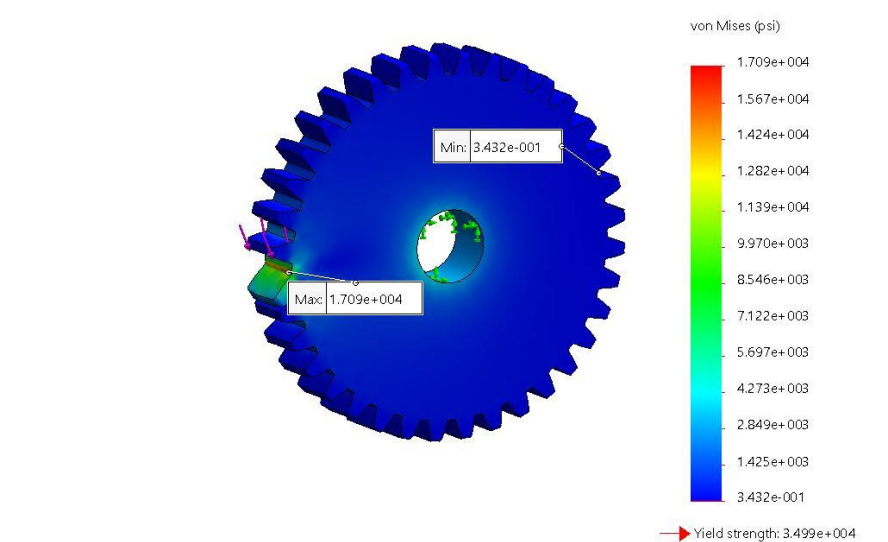

the large radius which can distribute the calculated moment acting on the center.

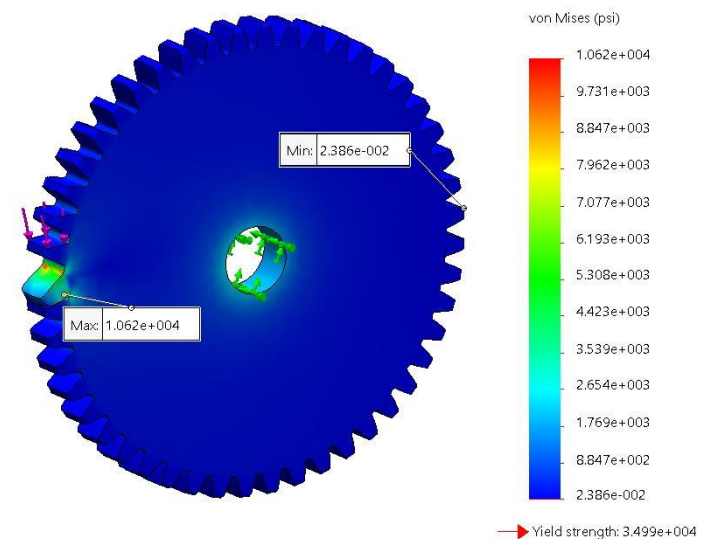

Manufacturing Detailed Drawings:

The following pages contain the manufacturing drawings for the shifting gearbox and planetary gearbox parts, respectively.

Complete Assembly Drawings:

The following pages contain the assembly drawings for the Shifting Gearbox and Planetary Gearbox, respectively.

Bill of Materials:

The Bill of Materials is as follows with different vendors designated by unique row coloring.

Item	Assembly	Description	Quantity	Source	Price Per	Total Price	P/N	Link
1	Planetary Gearbox	24T Gear, 24Pitch	1	McMaster-Carr	18.55	18.55	6832K62	https://www.mcmaster.com/6832k62
2		12T Gear, 24Pitch	3	McMaster-Carr	22.88	68.64	7880K37	https://www.mcmaster.com/7880k37
3		48T Internal Spur Gear	1	McMaster-Carr	142.52	142.52	2696N2	https://www.mcmaster.com/2696n2
4		Middle Housing	1	Aluminum Stock	-	-	-	-
5		Ball Bearing, 1/4OD, 1/8ID	6	McMaster-Carr	7.21	43.26	57155K205	https://www.mcmaster.com/57155k205
6		Custom Shaft Spacer	3	Rubber Stock	-	-	-	-
7		Custom Spacer Center	1	Rubber Stock	-	-	-	-
8		Motor Axle	3	Aluminum Rod Stock	-	-	-	-
9		Retaining Ring, 1/8OD	6	McMaster-Carr	6.16	6.16	97633A110	https://www.mcmaster.com/97633a110
10		DC Stepper Motor	1	McMaster-Carr	100.57	100.57	6627T33	https://www.mcmaster.com/6627t33
11		Button Table	1	Aluminum Stock	-	-	-	-
12		Press Button	6	Amazon.com	7.99	7.99	-	https://tinyurl.com/ycx7mehj
13		Button Plate	1	Aluminum Sheet Stock	-	-	-	-
14	Shifting Gearbox	12T Gear, 24Pitch	1	McMaster-Carr	22.88	22.88	7880K37	https://www.mcmaster.com/7880k37
15		60T Gear, 24Pitch	1	McMaster-Carr	36.05	36.05	6832K66	https://www.mcmaster.com/6832k66
16		36T Gear, 24Pitch	1	McMaster-Carr	38.69	38.69	7880K44	https://www.mcmaster.com/7880k44
17		24T Gear, 24Pitch	1	McMaster-Carr	18.55	18.55	6832K62	https://www.mcmaster.com/6832k62
18		48T Gear, 24Pitch	1	McMaster-Carr	33.05	33.05	6832K65	https://www.mcmaster.com/6832k65
19		Differential Gear	1	Metal 2D Printed	95	95	-	https://www.protolabs.com/services/3d-printing/
20		36T Gear, 24 Pitch, no	1	McMaster-Carr	38.69	38.69	7880K44	https://www.mcmaster.com/7880k44
21		Output Shaft	1	Aluminum Rod Stock	-	-	-	-
22		Input Shaft	1	Aluminum Rod Stock	-	-	-	-
23		Retaining Ring, 5/16OD	6	McMaster-Carr	5.5	5.5	98410A650	https://www.mcmaster.com/98410a650
24		Input Shaft Spacer	2	Rubber Stock	-	-	-	-
25		DC Motor	1	McMaster-Carr	131.53	131.53	6331K65	https://www.mcmaster.com/6331k65
26		Ball Bearing, 1/4ID, 3/8OD	4	McMaster-Carr	6.38	25.52	57155K303	https://www.mcmaster.com/57155k303
27		Motor Plate	1	Aluminum Stock	-	-	-	-
28		Clockage Plate	1	Aluminum Stock	-	-	-	-
29		Shifter Rod	1	Metal 2D Printed	-	-	-	see Differential Gear, Item 19
30		Standoffs, 1/4OD	4	McMaster-Carr	3.77	15.08	91125A493	https://www.mcmaster.com/91125a493
31		SHCS, 8-32x0.5	8	McMaster-Carr	10.74	10.74	91251A194	https://www.mcmaster.com/91251a194
Total Purchase:					858.97			

2

1

B

B

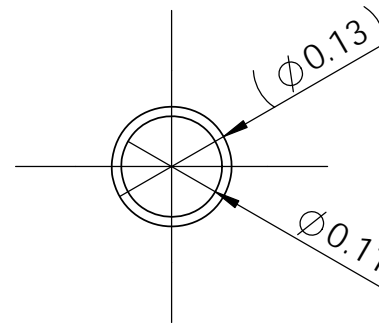
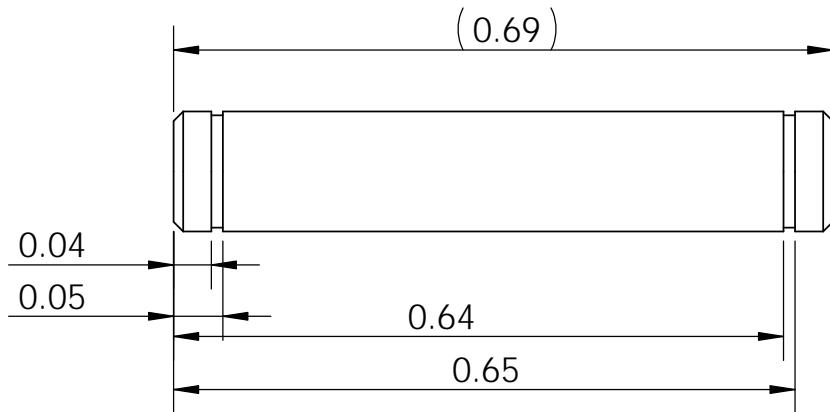
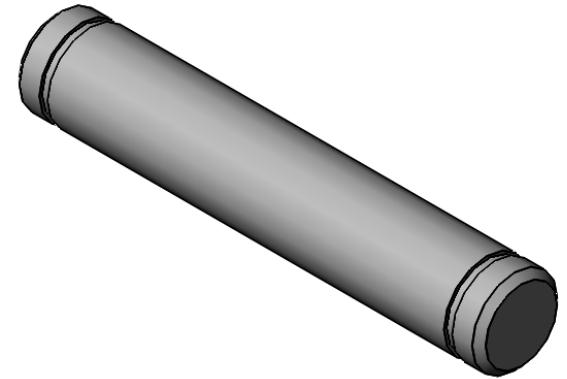

A

A

PROPRIETARY AND CONFIDENTIAL
 THE INFORMATION CONTAINED IN THIS DRAWING IS THE SOLE PROPERTY OF <INSERT COMPANY NAME HERE>. ANY REPRODUCTION IN PART OR AS A WHOLE WITHOUT THE WRITTEN PERMISSION OF <INSERT COMPANY NAME HERE> IS PROHIBITED.

		UNLESS OTHERWISE SPECIFIED:		NAME	DATE
		DIMENSIONS ARE IN INCHES	DRAWN	C. SEGAR	10/21/18
		TOLERANCES:	CHECKED		
		FRACTIONAL ±	ENG APPR.		
		ANGULAR: MACH ± BEND ±	MFG APPR.		
		TWO PLACE DECIMAL ±.03	Q.A.		
		THREE PLACE DECIMAL ±.01	COMMENTS:		
		INTERPRET GEOMETRIC TOLERANCING PER:			
		MATERIAL			
		6061 ALUMINUM			
		FINISH			
NEXT ASSY	USED ON				
APPLICATION		DO NOT SCALE DRAWING			

TITLE:		
Planet Gear Axle		
SIZE	DWG. NO.	REV
A		A
SCALE: 5:1	WEIGHT:	SHEET 1 OF 1

2

1

2

1

B

B

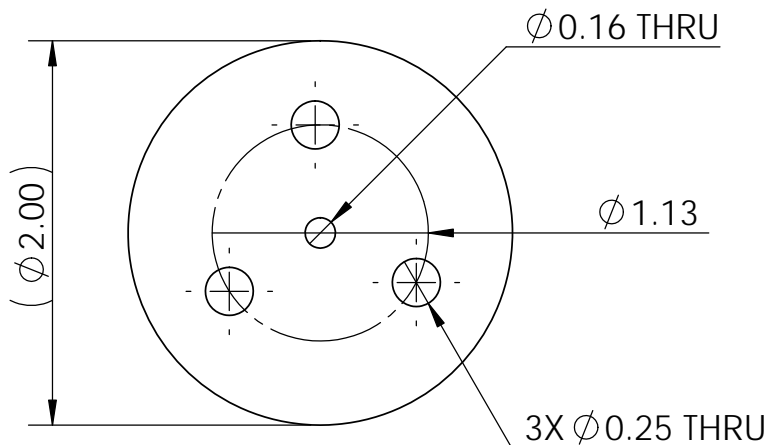
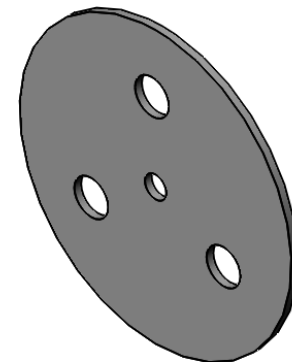
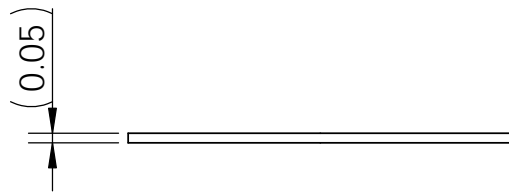

A

A

		UNLESS OTHERWISE SPECIFIED:		NAME	DATE	TITLE: Bottom Plate							
		DIMENSIONS ARE IN INCHES	DRAWN	C. SEGAR	10/21/18			SIZE A					
		TOLERANCES:	CHECKED							DWG. NO.			
		FRACTIONAL \pm	ENG APPR.									REV A	
		ANGULAR: MACH \pm BEND \pm	MFG APPR.										
		TWO PLACE DECIMAL $\pm .03$	Q.A.			WEIGHT:							
		THREE PLACE DECIMAL $\pm .01$	COMMENTS:			SHEET 1 OF 1							
		INTERPRET GEOMETRIC TOLERANCING PER:											
		MATERIAL											
		6061 ALUMINUM											
		FINISH											
	NEXT ASSY	USED ON											
	APPLICATION		DO NOT SCALE DRAWING										

PROPRIETARY AND CONFIDENTIAL
 THE INFORMATION CONTAINED IN THIS DRAWING IS THE SOLE PROPERTY OF <INSERT COMPANY NAME HERE>. ANY REPRODUCTION IN PART OR AS A WHOLE WITHOUT THE WRITTEN PERMISSION OF <INSERT COMPANY NAME HERE> IS PROHIBITED.

2

1

2

1

B

B

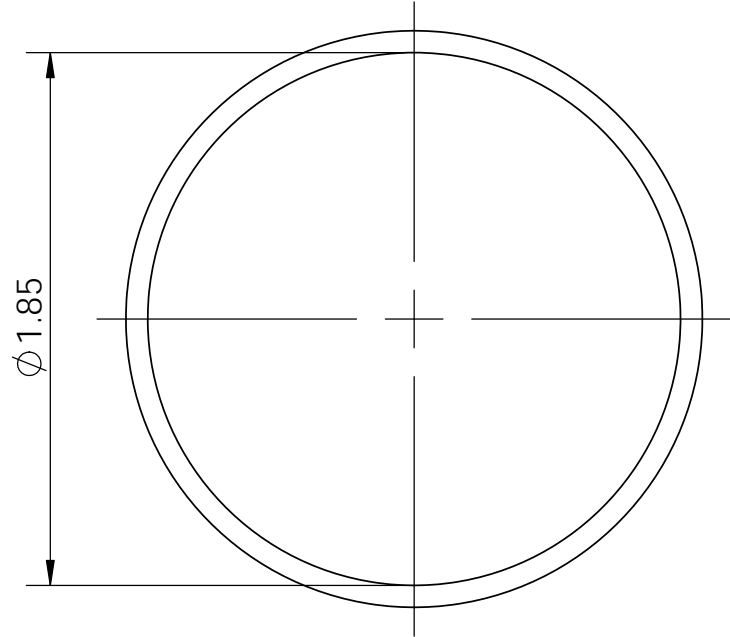
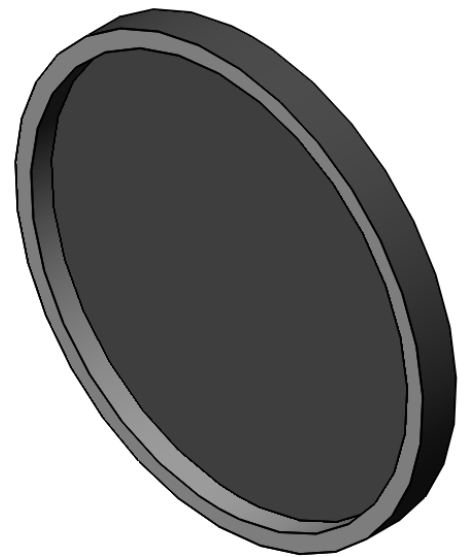
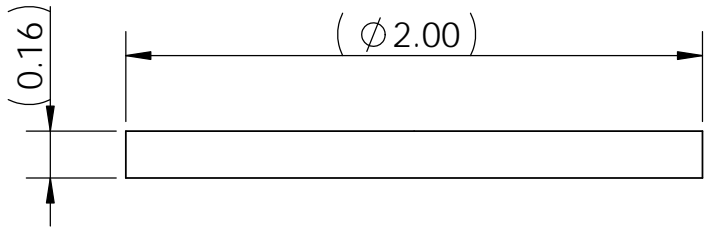

A

A

		UNLESS OTHERWISE SPECIFIED:		NAME	DATE	TITLE: Button Table			
		DIMENSIONS ARE IN INCHES	DRAWN	C. SEGAR	10/21/18			SIZE A	DWG. NO.
		TOLERANCES:	CHECKED						
		FRACTIONAL ±	ENG APPR.					SCALE: 1:1	WEIGHT:
		ANGULAR: MACH ± BEND ±	MFG APPR.					SHEET 1 OF 1	
		TWO PLACE DECIMAL ±.03	Q.A.						
		THREE PLACE DECIMAL ±.01	COMMENTS:						
		INTERPRET GEOMETRIC TOLERANCING PER:							
		MATERIAL							
		6061 ALUMINUM							
		FINISH							
	NEXT ASSY	USED ON							
	APPLICATION		DO NOT SCALE DRAWING						

PROPRIETARY AND CONFIDENTIAL
 THE INFORMATION CONTAINED IN THIS DRAWING IS THE SOLE PROPERTY OF <INSERT COMPANY NAME HERE>. ANY REPRODUCTION IN PART OR AS A WHOLE WITHOUT THE WRITTEN PERMISSION OF <INSERT COMPANY NAME HERE> IS PROHIBITED.

2

1

2

1

B

B

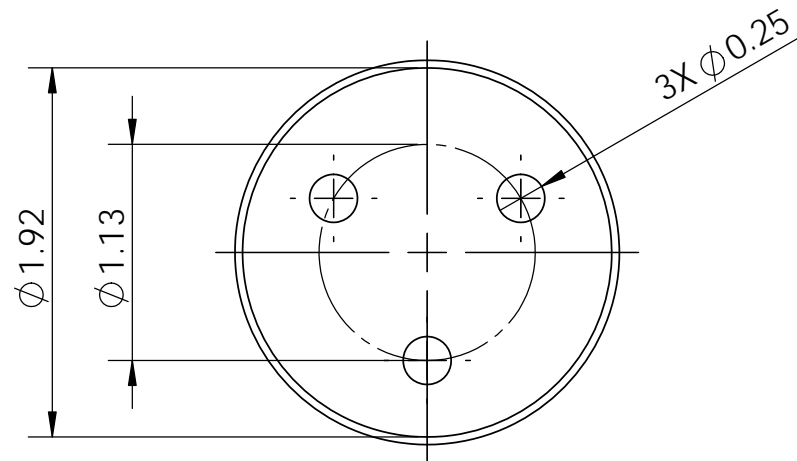
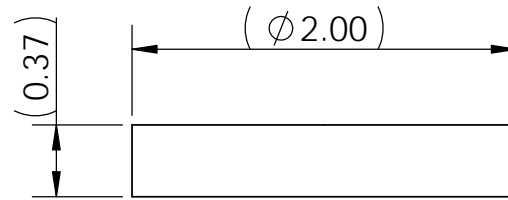
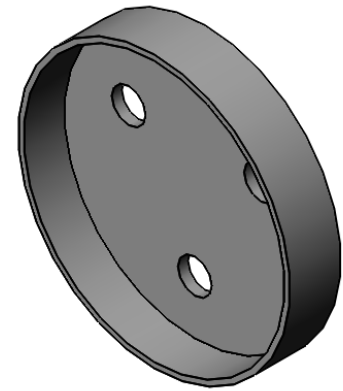

A

A

PROPRIETARY AND CONFIDENTIAL
 THE INFORMATION CONTAINED IN THIS DRAWING IS THE SOLE PROPERTY OF <INSERT COMPANY NAME HERE>. ANY REPRODUCTION IN PART OR AS A WHOLE WITHOUT THE WRITTEN PERMISSION OF <INSERT COMPANY NAME HERE> IS PROHIBITED.

		UNLESS OTHERWISE SPECIFIED:		NAME	DATE
		DIMENSIONS ARE IN INCHES	DRAWN	C. SEGAR	10/21/18
		TOLERANCES:	CHECKED		
		FRACTIONAL ±	ENG APPR.		
		ANGULAR: MACH ± BEND ±	MFG APPR.		
		TWO PLACE DECIMAL ±.03	Q.A.		
		THREE PLACE DECIMAL ±.01	COMMENTS:		
		INTERPRET GEOMETRIC TOLERANCING PER:			
		MATERIAL			
		6061 ALUMINUM			
		FINISH			
NEXT ASSY	USED ON				
APPLICATION		DO NOT SCALE DRAWING			

TITLE:		
Middle Housing		
SIZE	DWG. NO.	REV
A		A
SCALE: 1:1	WEIGHT:	SHEET 1 OF 1

2

1

2

1

B

B

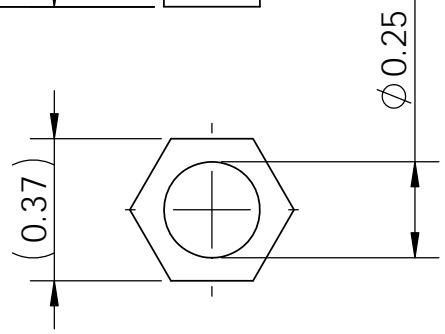
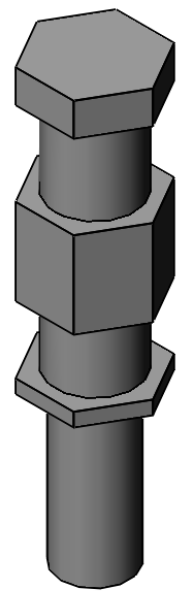
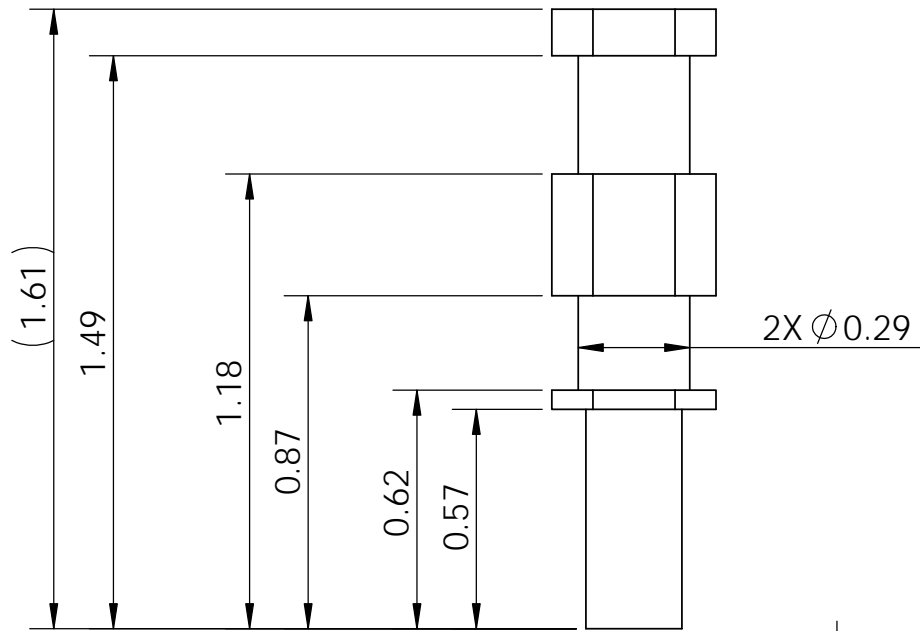

A

A

		UNLESS OTHERWISE SPECIFIED:		NAME	DATE	TITLE: Output Shaft				
		DIMENSIONS ARE IN INCHES		DRAWN	C. SEGAR			10/21/18		
		TOLERANCES:		CHECKED						
		FRACTIONAL \pm		ENG APPR.						
		ANGULAR: MACH \pm BEND \pm		MFG APPR.						
		TWO PLACE DECIMAL ± 0.03		Q.A.						
		THREE PLACE DECIMAL ± 0.01		COMMENTS:						
		INTERPRET GEOMETRIC TOLERANCING PER:		SIZE A			DWG. NO.		REV A	
		MATERIAL								
		6061 ALUMINUM								
		FINISH		SCALE: 2:1			WEIGHT:		SHEET 1 OF 1	
NEXT ASSY		USED ON		APPLICATION			DO NOT SCALE DRAWING			

PROPRIETARY AND CONFIDENTIAL
 THE INFORMATION CONTAINED IN THIS DRAWING IS THE SOLE PROPERTY OF <INSERT COMPANY NAME HERE>. ANY REPRODUCTION IN PART OR AS A WHOLE WITHOUT THE WRITTEN PERMISSION OF <INSERT COMPANY NAME HERE> IS PROHIBITED.

2

1

2 1

B

B

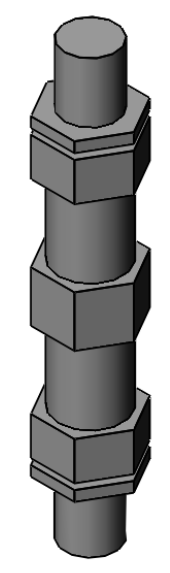
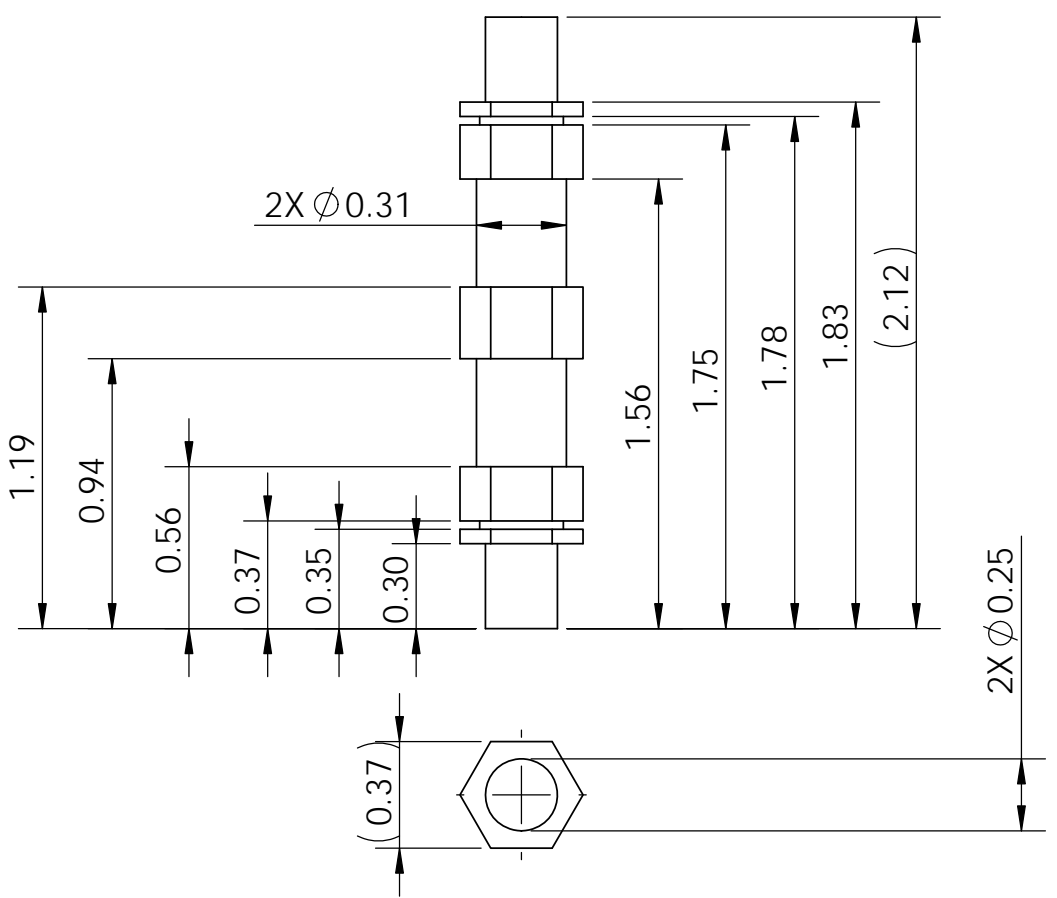

A

A

PROPRIETARY AND CONFIDENTIAL
 THE INFORMATION CONTAINED IN THIS DRAWING IS THE SOLE PROPERTY OF <INSERT COMPANY NAME HERE>. ANY REPRODUCTION IN PART OR AS A WHOLE WITHOUT THE WRITTEN PERMISSION OF <INSERT COMPANY NAME HERE> IS PROHIBITED.

		UNLESS OTHERWISE SPECIFIED:		NAME	DATE
		DIMENSIONS ARE IN INCHES	DRAWN	C. SEGAR	10/21/18
		TOLERANCES:	CHECKED		
		FRACTIONAL \pm	ENG APPR.		
		ANGULAR: MACH \pm BEND \pm	MFG APPR.		
		TWO PLACE DECIMAL $\pm .03$	Q.A.		
		THREE PLACE DECIMAL $\pm .01$	COMMENTS:		
		INTERPRET GEOMETRIC TOLERANCING PER:			
		MATERIAL			
		6061 ALUMINUM			
		FINISH			
NEXT ASSY	USED ON				
APPLICATION		DO NOT SCALE DRAWING			

TITLE:		
Input Shaft		
SIZE	DWG. NO.	REV
A		A
SCALE: 1:1	WEIGHT:	SHEET 1 OF 1

2

1

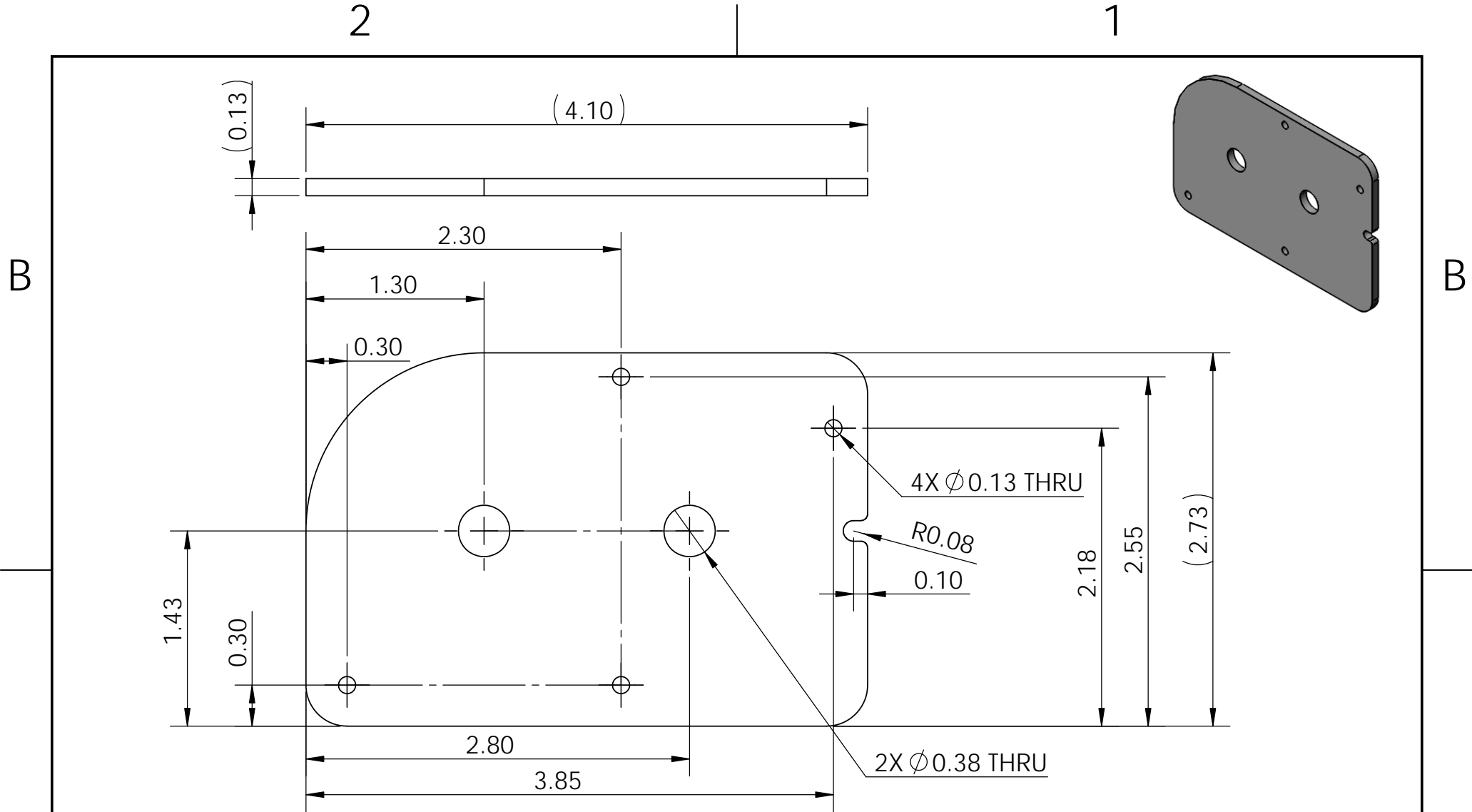

A

A

PROPRIETARY AND CONFIDENTIAL
 THE INFORMATION CONTAINED IN THIS DRAWING IS THE SOLE PROPERTY OF <INSERT COMPANY NAME HERE>. ANY REPRODUCTION IN PART OR AS A WHOLE WITHOUT THE WRITTEN PERMISSION OF <INSERT COMPANY NAME HERE> IS PROHIBITED.

		UNLESS OTHERWISE SPECIFIED:		NAME	DATE
		DIMENSIONS ARE IN INCHES	DRAWN	C. SEGAR	10/21/18
		TOLERANCES:	CHECKED		
		FRACTIONAL ±	ENG APPR.		
		ANGULAR: MACH ± BEND ±	MFG APPR.		
		TWO PLACE DECIMAL ±.03	Q.A.		
		THREE PLACE DECIMAL ±.01	COMMENTS:		
		INTERPRET GEOMETRIC TOLERANCING PER:			
		MATERIAL			
		6061 ALUMINUM			
		FINISH			
NEXT ASSY	USED ON				
APPLICATION		DO NOT SCALE DRAWING			

TITLE:
Clockcage Plate

SIZE	DWG. NO.	REV
A		A
SCALE: 1:2	WEIGHT:	SHEET 1 OF 1

2

1

B

B

A

A

2

1

B

B

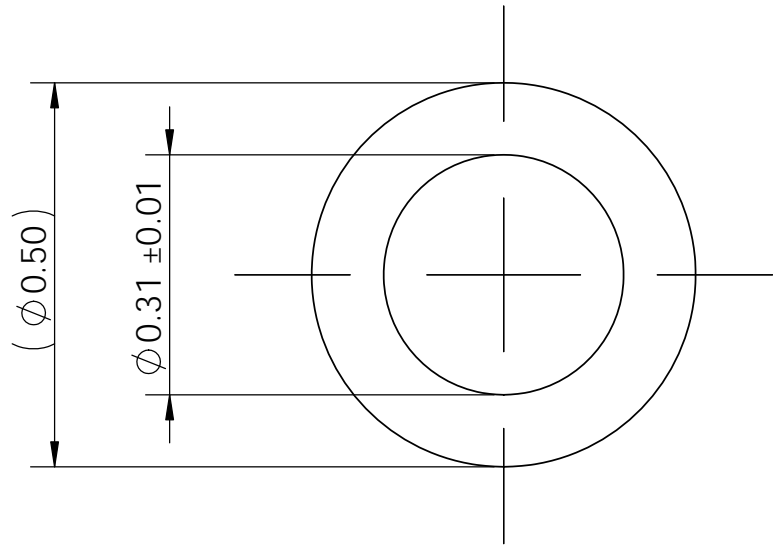
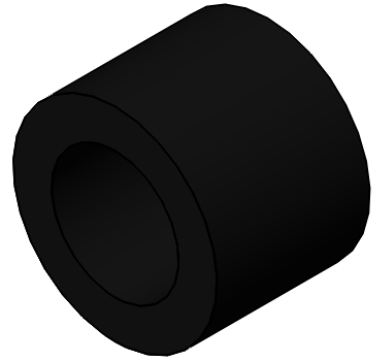
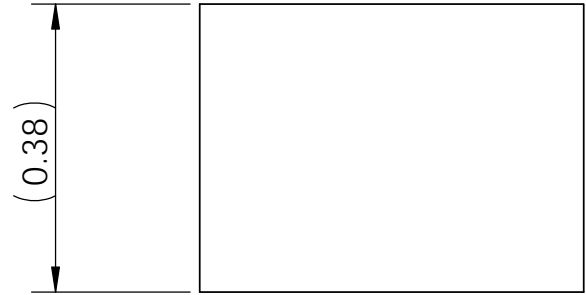

A

A

		UNLESS OTHERWISE SPECIFIED:		NAME	DATE
		DIMENSIONS ARE IN INCHES	DRAWN	C. SEGAR	10/21/18
		TOLERANCES:	CHECKED		
		FRACTIONAL ±	ENG APPR.		
		ANGULAR: MACH ± BEND ±	MFG APPR.		
		TWO PLACE DECIMAL ±.03	Q.A.		
		THREE PLACE DECIMAL ±.01	COMMENTS:		
		INTERPRET GEOMETRIC TOLERANCING PER:			
		MATERIAL	UNCOATED RUBBER		
		FINISH			
	NEXT ASSY	USED ON			
	APPLICATION		DO NOT SCALE DRAWING		

PROPRIETARY AND CONFIDENTIAL
 THE INFORMATION CONTAINED IN THIS DRAWING IS THE SOLE PROPERTY OF <INSERT COMPANY NAME HERE>. ANY REPRODUCTION IN PART OR AS A WHOLE WITHOUT THE WRITTEN PERMISSION OF <INSERT COMPANY NAME HERE> IS PROHIBITED.

TITLE: Input Shaft Spacer		
SIZE A	DWG. NO.	REV A
SCALE: 5:1	WEIGHT:	SHEET 1 OF 1

2

1

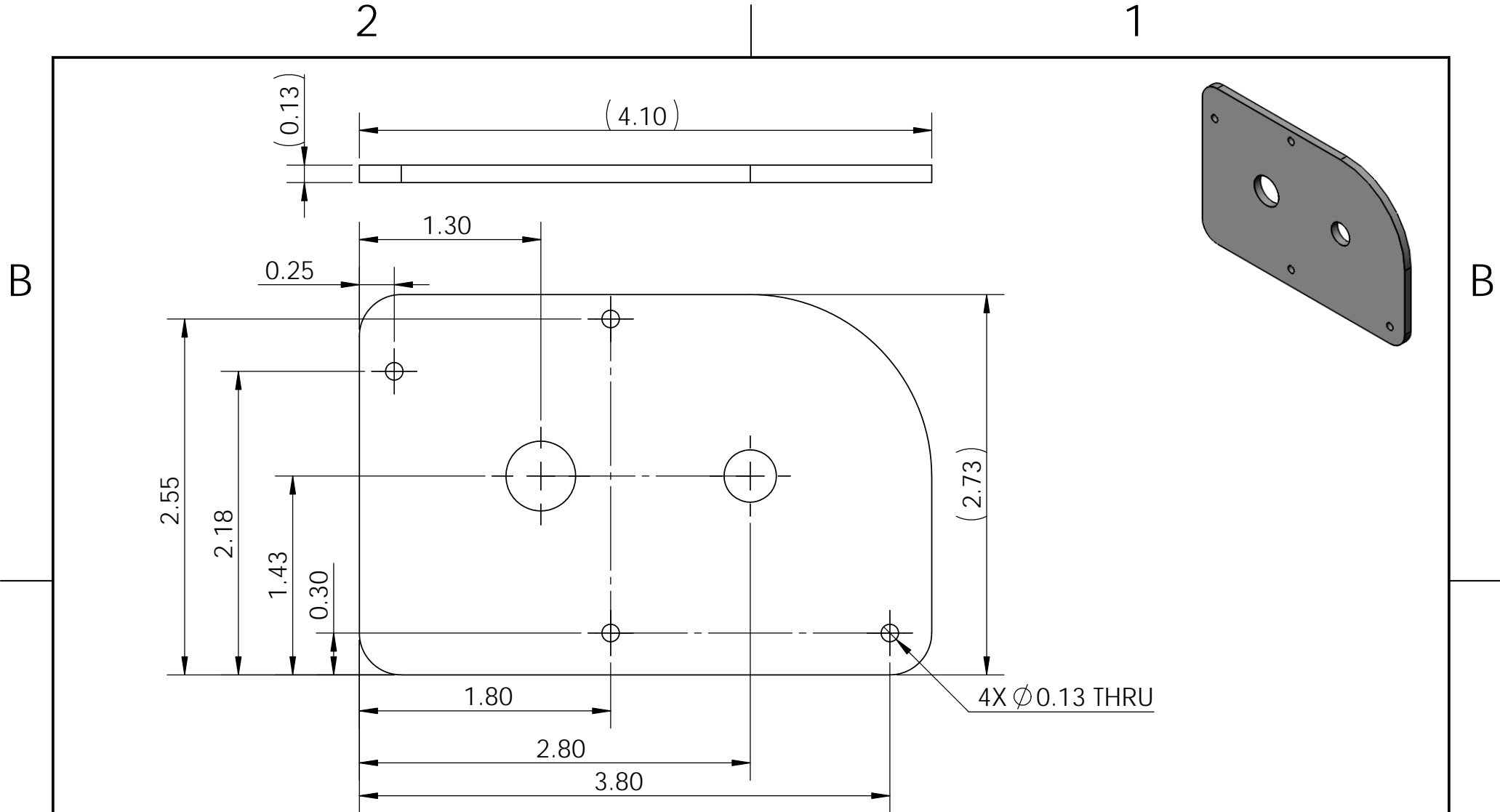

A

A

PROPRIETARY AND CONFIDENTIAL
 THE INFORMATION CONTAINED IN THIS DRAWING IS THE SOLE PROPERTY OF <INSERT COMPANY NAME HERE>. ANY REPRODUCTION IN PART OR AS A WHOLE WITHOUT THE WRITTEN PERMISSION OF <INSERT COMPANY NAME HERE> IS PROHIBITED.

		UNLESS OTHERWISE SPECIFIED:		NAME	DATE
		DIMENSIONS ARE IN INCHES	DRAWN	C. SEGAR	10/21/18
		TOLERANCES:	CHECKED		
		FRACTIONAL ±	ENG APPR.		
		ANGULAR: MACH ± BEND ±	MFG APPR.		
		TWO PLACE DECIMAL ±.03	Q.A.		
		THREE PLACE DECIMAL ±.01	COMMENTS:		
		INTERPRET GEOMETRIC TOLERANCING PER:			
		MATERIAL			
		6061 ALUMINUM			
		FINISH			
NEXT ASSY	USED ON				
APPLICATION		DO NOT SCALE DRAWING			

TITLE:		
Motor Plate		
SIZE	DWG. NO.	REV
A		A
SCALE: 1:2	WEIGHT:	SHEET 1 OF 1

2

1

B

B

2

1

B

B

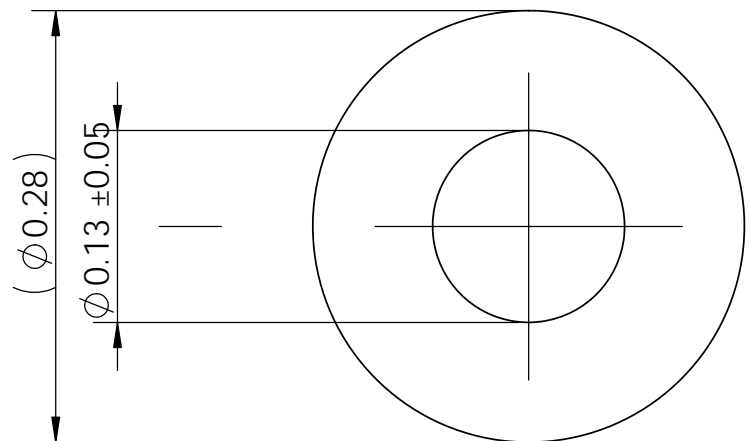
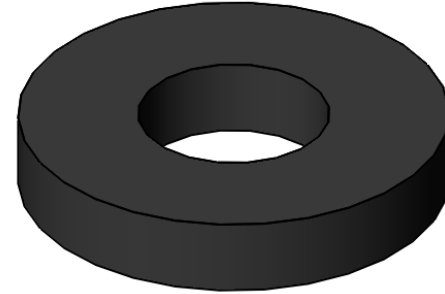
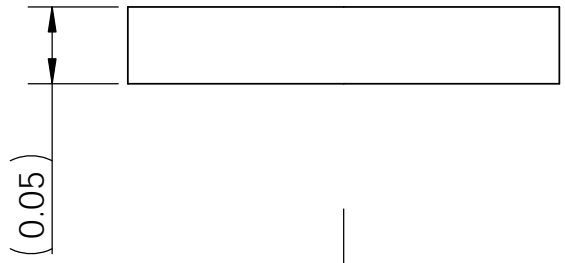

A

A

		UNLESS OTHERWISE SPECIFIED:		NAME	DATE	TITLE: <h1>Custom Shaft Spacer</h1>			
		DIMENSIONS ARE IN INCHES	DRAWN	C. SEGAR	10/21/18			SIZE A	DWG. NO.
		TOLERANCES:	CHECKED						
		FRACTIONAL \pm	ENG APPR.						
		ANGULAR: MACH \pm BEND \pm	MFG APPR.						
		TWO PLACE DECIMAL $\pm .03$	Q.A.			SCALE: 10:1	WEIGHT:		
		THREE PLACE DECIMAL $\pm .01$	COMMENTS:			SHEET 1 OF 1			
		INTERPRET GEOMETRIC TOLERANCING PER:							
		MATERIAL							
		UNCOATED RUBBER							
		FINISH							
NEXT ASSY	USED ON	APPLICATION	DO NOT SCALE DRAWING						

PROPRIETARY AND CONFIDENTIAL
 THE INFORMATION CONTAINED IN THIS DRAWING IS THE SOLE PROPERTY OF <INSERT COMPANY NAME HERE>. ANY REPRODUCTION IN PART OR AS A WHOLE WITHOUT THE WRITTEN PERMISSION OF <INSERT COMPANY NAME HERE> IS PROHIBITED.

2

1

2

1

B

B

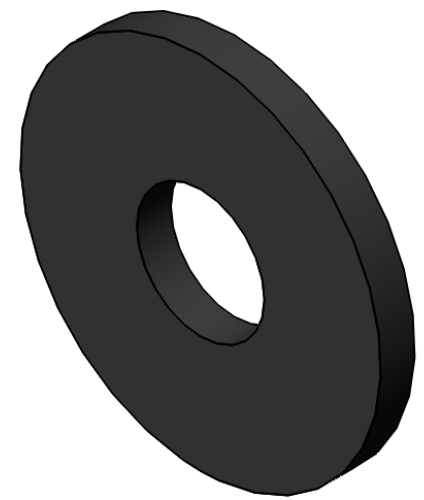
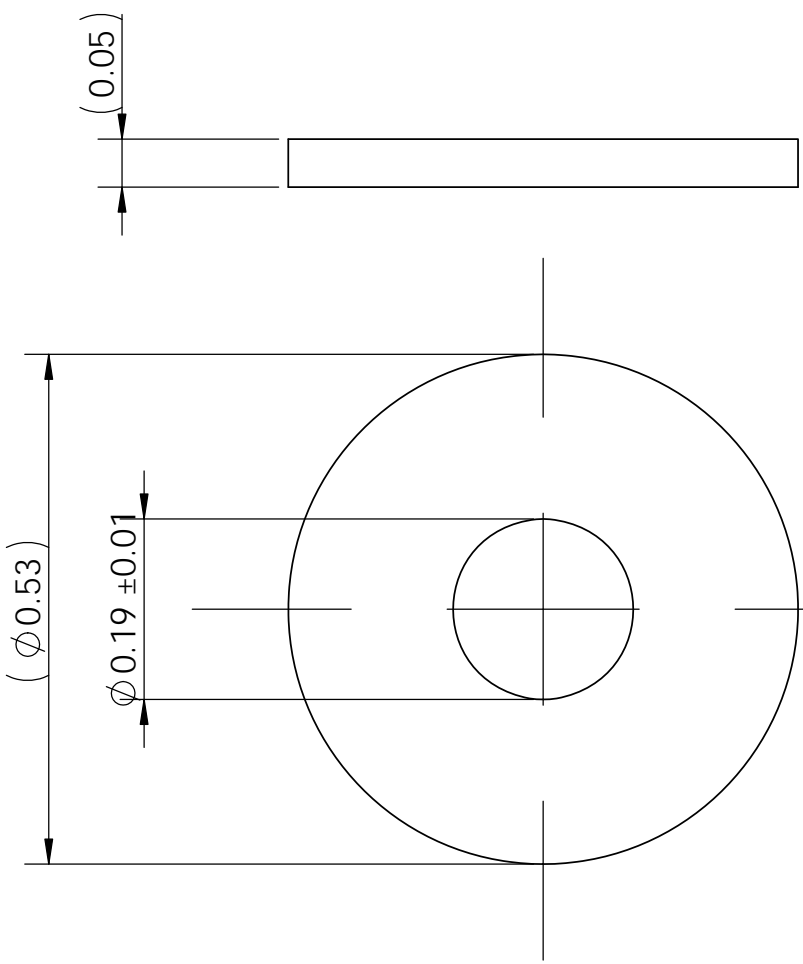

A

A

PROPRIETARY AND CONFIDENTIAL
 THE INFORMATION CONTAINED IN THIS DRAWING IS THE SOLE PROPERTY OF <INSERT COMPANY NAME HERE>. ANY REPRODUCTION IN PART OR AS A WHOLE WITHOUT THE WRITTEN PERMISSION OF <INSERT COMPANY NAME HERE> IS PROHIBITED.

		UNLESS OTHERWISE SPECIFIED:		NAME	DATE
		DIMENSIONS ARE IN INCHES	DRAWN	C. SEGAR	10/21/18
		TOLERANCES:	CHECKED		
		FRACTIONAL ±	ENG APPR.		
		ANGULAR: MACH ± BEND ±	MFG APPR.		
		TWO PLACE DECIMAL ±.03	Q.A.		
		THREE PLACE DECIMAL ±.01	COMMENTS:		
		INTERPRET GEOMETRIC TOLERANCING PER:			
		MATERIAL			
		UNCOATED RUBBER			
		FINISH			
NEXT ASSY	USED ON				
APPLICATION		DO NOT SCALE DRAWING			

TITLE:
Custom Spacer Center

SIZE	DWG. NO.	REV
A		A
SCALE: 5:1	WEIGHT:	SHEET 1 OF 1

2

1

2

1

SECTION A-A

SCALE 1 : 1

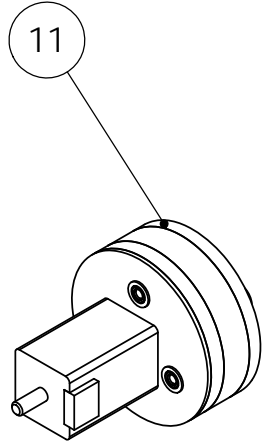
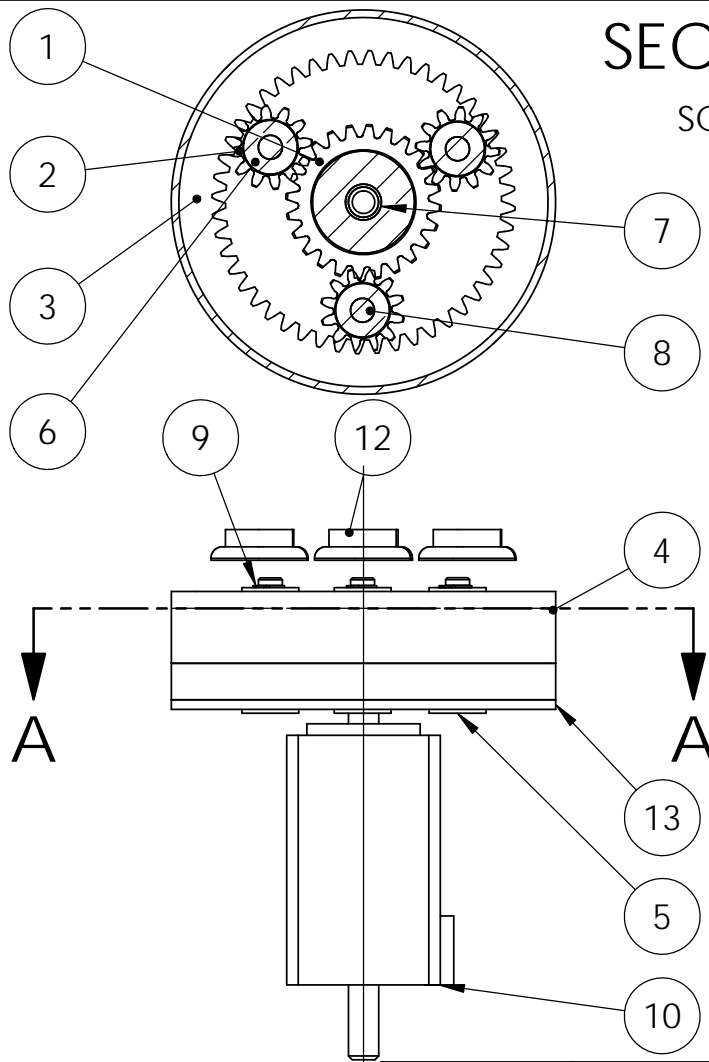

ITEM NO.	PART NUMBER	QTY.
1	24T_0.75inPD	1
2	12T_0.375inPD	3
3	48T_0.75PD-internal	1
4	Middle Housing	1
5	57155K205-ballBearing	6
6	Custom Shaft Spacer	3
7	Custom Spacer Center	1
8	Motor Axle	3
9	97633A110-retainingRing	6
10	6627T330-DCStepperMotor	1
11	Button Table	1
12	Button	6
13	Bottom Plate	1

B

B

A

A

PROPRIETARY AND CONFIDENTIAL
 THE INFORMATION CONTAINED IN THIS DRAWING IS THE SOLE PROPERTY OF <INSERT COMPANY NAME HERE>. ANY REPRODUCTION IN PART OR AS A WHOLE WITHOUT THE WRITTEN PERMISSION OF <INSERT COMPANY NAME HERE> IS PROHIBITED.

		UNLESS OTHERWISE SPECIFIED:		NAME	DATE
		DIMENSIONS ARE IN INCHES	DRAWN	C. SEGAR	10/21/18
		TOLERANCES:	CHECKED		
		FRACTIONAL ±	ENG APPR.		
		ANGULAR: MACH ± BEND ±	MFG APPR.		
		TWO PLACE DECIMAL ±.03	Q.A.		
		THREE PLACE DECIMAL ±.01	COMMENTS:		
		INTERPRET GEOMETRIC TOLERANCING PER:			
		MATERIAL			
		FINISH			
NEXT ASSY	USED ON				
APPLICATION		DO NOT SCALE DRAWING			

TITLE:		
<h1>Planetary Gearbox</h1>		
SIZE	DWG. NO.	REV
A		A
SCALE: 1:2	WEIGHT:	SHEET 1 OF 1

2

1

2

1

B

B

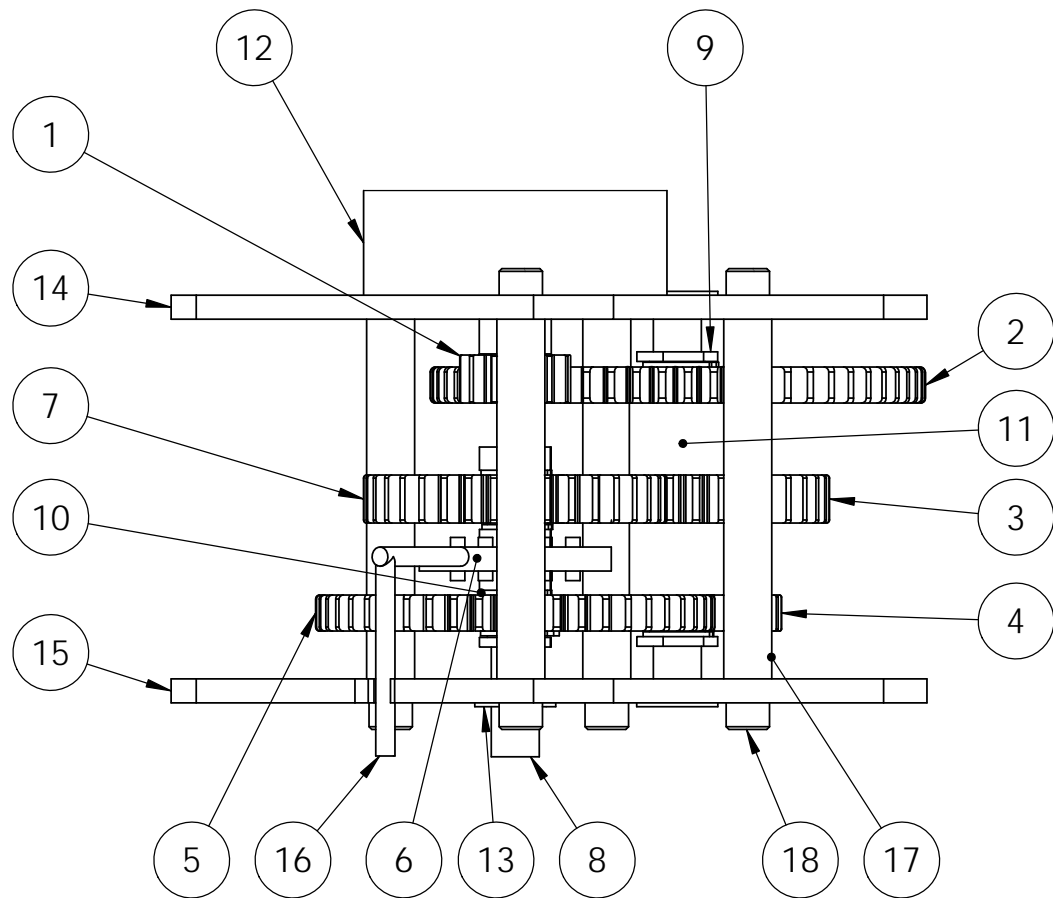

ITEM NO.	PART NUMBER	QTY.
1	7880K370-12T	1
2	6832K660-60T	1
3	7880K440-36T	1
4	6832K620-24T	1
5	6832K650-48T	1
6	Differential Gear	1
7	7880K440-36T-noHub	1
8	Output Shaft	1
9	Input Shaft	1
10	98410A650-retainingRing	6
11	Input Shaft Spacer	2
12	6331K650-DCMotor	1
13	57155K303-ballBearing	4
14	Motor Plate	1
15	Clockcase Plate	1
16	Shift Rod	1
17	91125A493-standoffs	4
18	HX-SHCS 0.138-32x0.5x0.5-N	8

A

A

		UNLESS OTHERWISE SPECIFIED:		NAME	DATE
		DIMENSIONS ARE IN INCHES	DRAWN	C. SEGAR	10/21/18
		TOLERANCES:	CHECKED		
		FRACTIONAL ±	ENG APPR.		
		ANGULAR: MACH ± BEND ±	MFG APPR.		
		TWO PLACE DECIMAL ±.03	Q.A.		
		THREE PLACE DECIMAL ±.01	COMMENTS:		
		INTERPRET GEOMETRIC TOLERANCING PER:			
		MATERIAL			
		FINISH			
	NEXT ASSY	USED ON			
	APPLICATION				
		DO NOT SCALE DRAWING			

PROPRIETARY AND CONFIDENTIAL
 THE INFORMATION CONTAINED IN THIS DRAWING IS THE SOLE PROPERTY OF <INSERT COMPANY NAME HERE>. ANY REPRODUCTION IN PART OR AS A WHOLE WITHOUT THE WRITTEN PERMISSION OF <INSERT COMPANY NAME HERE> IS PROHIBITED.

TITLE:
Shifting Gearbox

SIZE A	DWG. NO.	REV A
SCALE: 1:5	WEIGHT:	SHEET 1 OF 1

2

1